

BELT DRIVE CD PLAYER

TL53Z

Owner's Manual

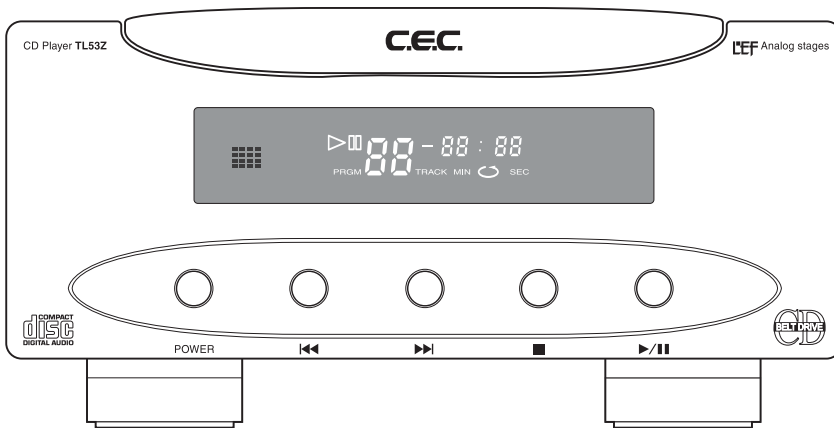

C.E.C.

Contents

• Introduction	2
• Important Safety Instructions	4
• Handling Precautions	6
• Compact Disc Handling	8
• Accessories	10
• Front Panel Functions	11
• Inside the CD Door	13
• Rear Panel Functions	14
• Operation	16
• Remote Control Unit	18
• Programmed Playback	20
• Precautions on Using the Remote Control Unit	22
• Cautions Regarding Handling	23
• Maintenance	24
• Troubleshooting	25
• Specifications	26

Introduction

Thank you for purchasing the TL53Z.

Please read through and refer to this Owner's Manual to use your TL53Z safely and adequately. It is recommended that you keep the unit's packaging available for future transportation needs.

Features:

- The TL53Z CD player uses CEC's proprietary belt drive mechanism that minimizes the vibration and electromagnetic noise from the motors, enabling the precise reproduction of music signals. The top-loading design allows the use of a stabilizer for maximum disc stability.
- The TL53Z uses the Burr Brown "PCM1792" DAC in a left/right-independent dual/mono configuration with balanced current output. The $\Delta\Sigma$ -Over sampling setting allows fine adjustment of the sound characteristics (32fs, 64fs,128fs), and the Digital Filter can be set to 2 different characteristics: "Flat", which offers best

frequency response and sharp filtering of ultrasonic noise, and "Pulse", which is optimized for the best dynamic response.

- The TL53Z uses a newly developed low-jitter crystal oscillator circuit, which forms the basis for accurate and dynamic playback.
- The cutting-edge version of CEC's proprietary Current-Injection circuit, which converts the DAC output current into an output voltage without any negative feedback circuitry, combined with the TL53Z's unique LEF circuit, offers even more improvement in sound quality. The analog circuit is basically a balanced design with an extremely short signal path.
- The TL53Z uses an advanced switching power supply with an integrated AC line power purifier to avoid issues caused by the AC power line. It also has separate power supplies for its Transport and DAC sections, and independent voltage for its motor, servo, display, digital and analog circuitries.

Important Safety Instructions



The lightning flash with arrowhead symbol, within an equilateral triangle, is intended to alert the user to potential electric shock hazards within the product's enclosure.



The exclamation point within an equilateral triangle is intended to notify the user to the presence of important operating and maintenance (servicing) instructions in the accompanying documentation.

WARNING : TO PREVENT FIRE OR SHOCK HAZARD, DO NOT EXPOSE THIS APPLIANCE TO RAIN OR MOISTURE.

- 1) Read these instructions.
- 2) Keep these instructions.
- 3) Heed all warnings.
- 4) Follow all instructions
- 5) Do not use the TL53Z near water.
- 6) Clean only with a dry cloth.
- 7) Do not block any ventilation openings. Install in accordance with the manufacturer's instructions.
- 8) Do not install the TL53Z near any heat sources such as radiators, heat registers, stoves, or other apparatus (including amplifiers) that produce heat.
- 9) (For USA, Canada:) Do not defeat the safety purpose of the polarized or grounding-type plug. A polarized plug has two blades, with one blade wider than the other. A grounding type plug has two blades and a third grounding prong. The wide blade or the third prong is provided for your safety. If the provided plug does not fit your outlet, consult an electrician for replacement of the obsolete outlet. (For European Countries:) Do not defeat the safety purpose of the grounding-type plug. This plug has two poles and a third grounding hole. The third hole is provided for your safety. If the provided plug does not fit your outlet, consult an electrician for replacement of the obsolete outlet.

- 10) Protect the AMP53's power cord from being walked on or pinched, especially around the plugs, convenience receptacles, and where it exits the TL53Z's casing.
 - 11) Only use attachments/accessories specified by the manufacturer.
 - 12) Only use the TL53Z with a cart, stand, tripod, bracket, or table specified by the manufacturer or sold with the unit.
If using a cart, exercise caution when moving the cart/unit combination to avoid injury from it tipping over.
 - 13) Unplug the TL53Z during lightning storms or when leaving it unused for extended periods of time.
 - 14) Refer all servicing to qualified service personnel. Servicing is required when the TL53Z itself, its power-supply cord, or plug has been damaged in any way, when liquids have been spilled onto the TL53Z, when foreign objects have fallen into the TL53Z, when the TL53Z has been exposed to rain or moisture, when the TL53Z does not operate normally, or when the TL53Z has been dropped.
- Do not expose the TL53Z to drips or splashes.
 - Do not place any objects filled with liquids, such as vases, on the TL53Z.
 - Do not install the TL53Z in a confined space, such as within a bookcase or similar piece of furniture.
 - Plug the AC power cord into an easily accessible AC wall outlet, so it can be quickly unplugged in case of emergency.



CAUTION

- DO NOT REMOVE THE PROTECTIVE HOUSING WITH A SCREWDRIVER.
- USE OF CONTROLS OR ADJUSTMENTS OR PERFORMANCE OF PROCEDURES OTHER THAN THOSE SPECIFIED HEREIN MAY RESULT IN HAZARDOUS RADIATION EXPOSURE.
- IF THE TL53Z SEEMS TO BE MALFUNCTIONING, CONTACT A QUALIFIED SERVICE STATION. DISCONTINUE USE OF ANY MALFUNCTIONING UNIT.

For CANADA

AC POWER CORD CONNECTION

CAUTION:

TO PREVENT ELECTRIC SHOCK, MATCH THE BLADE WIDTH OF THE PLUG TO THE SLOT WIDTH. THE PLUG MUST BE FULLY INSERTED TO THE SLOT.

Handling Precautions

1. Connecting Other Devices

Unplug the TL53Z's AC power cord from the outlet before connecting or disconnecting other devices. Exercise caution when handling the AC power cord. When disconnecting the AC cord from a socket, make sure you pull the plug, and not the cord itself.

2. Turning Power On/Off

Your system components should be turned on/off in the following order to avoid generating noise from your speakers and damaging the speakers themselves or other devices:

Turning power on: Turn on the TL53Z's power first, before turning on the amplifier connected to the TL53Z.

Turning power off: Turn off the amplifier's power first, before turning off the TL53Z.

3. Optical Semiconductor Laser Pickup

The optical pickup is one of the important components that determine the performance of a CD player. Never touch the optical lens of the pickup with your fingers, etc. Close the CD door to keep the lens clean when not in use.

4. CD Stabilizer

Only use the provided CD stabilizer with the TL53Z. Commercially available stabilizers may cause the unit to malfunction.

5. Handle With Care

Avoid exerting excessive force on the knobs, the cabinet and the CD-turntable on the TL53Z.

6. Installation

Use of an audio rack is recommended to maximize the sound quality and performance of the TL53Z. Installation and use of the TL53Z in the locations described below may cause deterioration in sound quality or malfunction:

- Locations exposed to direct sunlight, such as windowsills, and other exceptionally warm locations, such as near heating appliances (surrounding temperature higher

than 35 °C), or exceptionally cold locations (surrounding temperature lower than 10 °C), may prevent the TL53Z from functioning adequately.

- Damp locations exceeding 90% humidity may cause the TL53Z's metal parts to rust, causing the unit to malfunction.
- Dusty locations may cause the TL53Z to malfunction. The accumulation of dust inside the CD door may lower the performance of music signal reading. It may also cause contact failure of the switches, and/or noise.
- Otherwise, avoid installing the TL53Z close to other transformers and electrical motors, so as to prevent the pickup of induction hum. Also, avoid mounting the unit on surfaces that may be affected by vibration.

7. Avoid lightning strikes

Disconnect the AC power cord from the AC outlet when there is a thunderstorm in your vicinity.

8. Condensation

When the TL53Z is brought into a warm room when the exterior temperature is cold, or when the room temperature rises sharply from using a heater, condensation may form both inside and outside the unit, hampering its performance. If this happens, leave the TL53Z unused in the room for 1 to 2 hours (depending on the amount of condensation), so as to bring the unit's temperature closer to the room temperature. The condensation should go away gradually.

9. Listening etiquette

When adjusting the sound volume level, make sure you do not disturb other people and your neighborhood.

Compact Disc Handling

- Since a compact disc can be played or recorded only on one side, discs should always be placed on the turntable with the label side up.

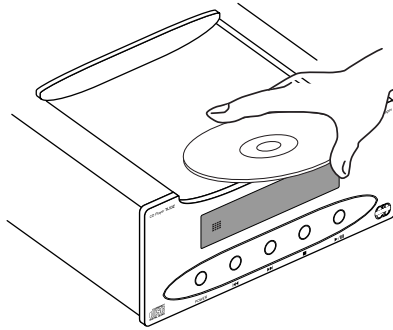

- When taking a compact disc from its case, lift it out by holding the edge of the disc while pressing down on the center button of the case.

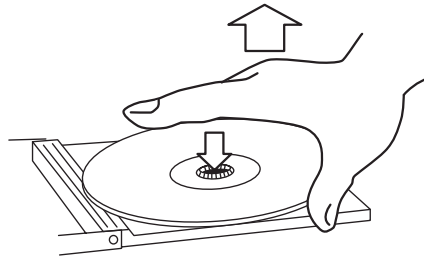

- Handle compact discs with care so as not to scratch their surfaces. Scratches, fingerprints or soiling may cause reading errors during playback.
- If a compact disc's surface becomes soiled, wipe it directly away from the disc's center with a soft, dry cloth. Try to keep the discs clean at all times.

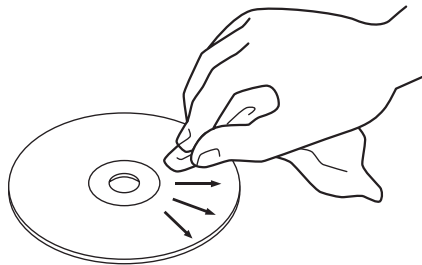

- Never use chemicals such as record sprays, anti-static sprays, benzene or thinner to clean a disc. These may corrode the surface of a disc.
- Do not place discs in any locations subject to high temperatures and high humidity, or that receive direct sunlight. Keep discs away from radiators and electrical heaters. CD-R and CD/RW discs are especially sensitive to ultraviolet rays, so keep

them out of direct sunlight.

- To avoid dust and scratching or warping of discs that could cause reading errors, replace discs in their cases after use.
- Do not attach any labels on a disc surfaces. Do not use discs that have Scotch tape, labels, excessive label glue exposed on the surface. These may cause the the TL53Z to malfunction.
- Do not use cracked discs or an irregularly shaped discs (octagonal, heart-shaped, or any other special shapes). These may cause the unit to malfunction.

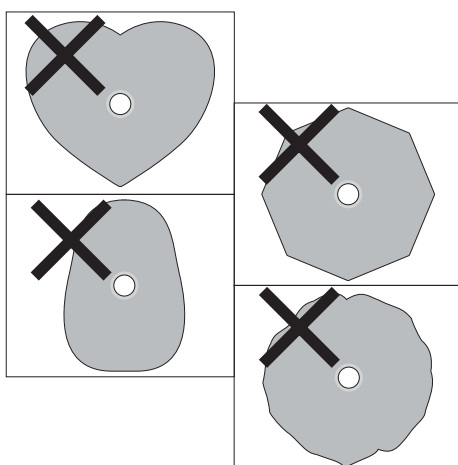

CD-R/RW DISC

- The TL53Z is able to playback CD-R/RW discs recorded in audio CD format and finalized. Some CD-R/RW discs may be unplayable due to the quality of the CD-R/RW disc and/or the quality of the recording.
- Do not attach stickers or protective seals on discs and do not use any protective coating sprays. If you wish to label a disc, only write on the label side using soft-tipped insoluble pens. Never use ballpoint pens or hard-tipped pens.

NONSTANDARD DISC

- Copy-protected discs and nonstandard discs may not be playable with this player. If you experience any problems with non-standard discs, contact the manufacturer of the disc first.

Accessories

The packaging for the TL53Z should contain the following:

1. TL53Z unit
2. Stabilizer
3. AC power cord
4. Remote control unit
5. Two AA batteries for the remote control unit
6. Owner's Manual

Note: Keep the packaging available for future transportation needs.

The AC power cord is for use with the TL53Z exclusively, and should not be used for other devices.

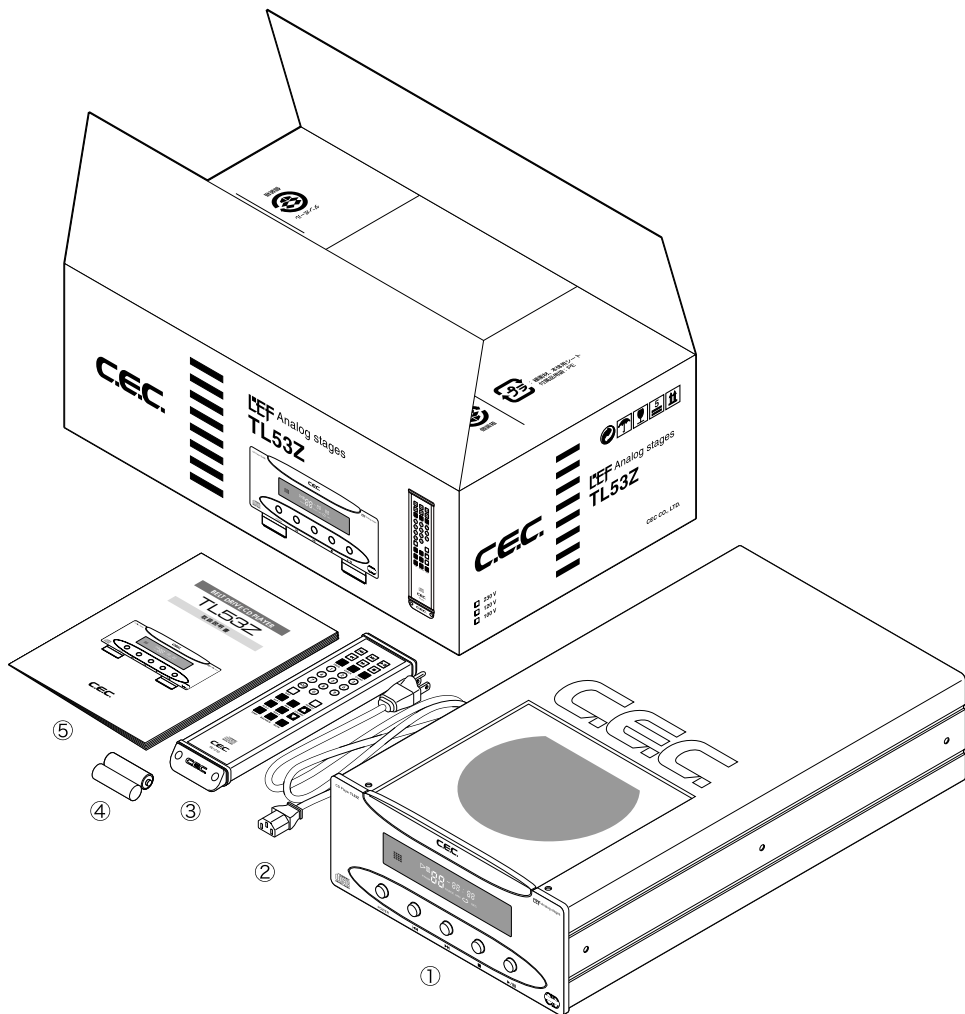

Front Panel Functions

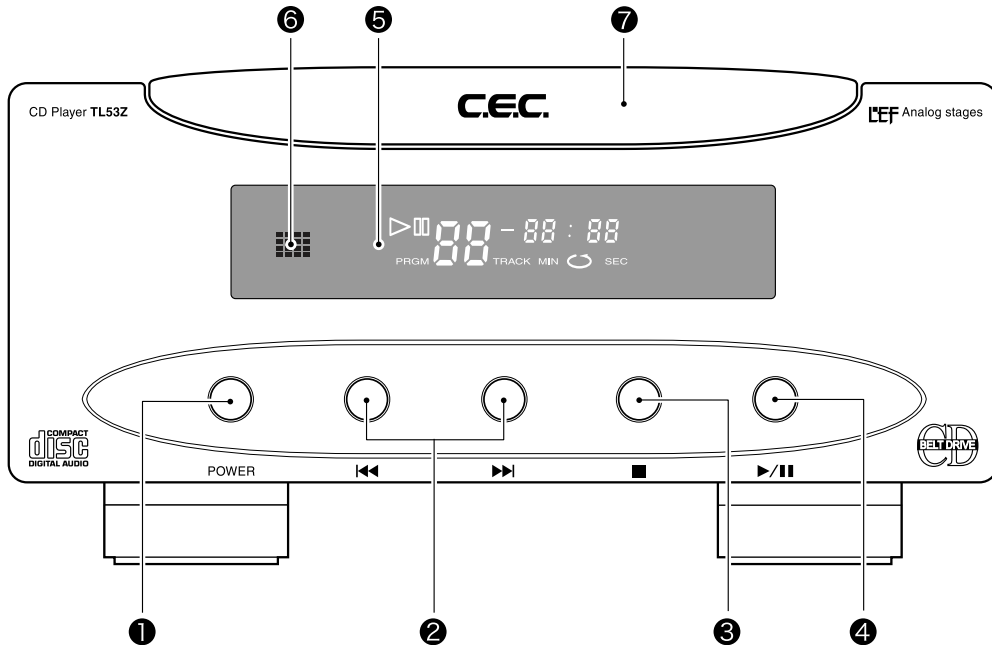

❶ POWER Button

Push this button to turn the power ON or OFF.

When the TL53Z is turned on, the display will blink "00:00" and the unit will check its tray for a compact disc. Approximately 5 seconds later, the display will change to indicate the total number of tracks and the total playing time. If there is no disc on the tray, the display will indicate "no disc".

NOTE: Approximately 10 seconds after turning the TL53Z on, you will hear a small click from the unit as the analog output relay switch activates. Since this sound may be amplified and result in noise from your speakers, wait for at least 10 seconds before turning your amplifier on, or turning up its volume.

❷ Track Skip Buttons (⏮ / ⏭)

Jumps to the next or previous track on the disc during playback.

❸ Stop Button (■)

Press this button to stop playback.

④ PLAY/PAUSE (▶/||)Button

Press this button to start (or to temporarily stop) playback.

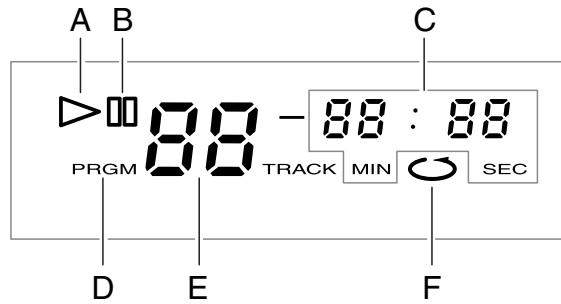
⑤ Display

- A. ▷ Playback indicator: lights up during playback
- B. ||| Pause indicator: blinks during pause mode
- C. Time display: indicates the elapsed time/remaining time for the track being played, total remaining time or total elapsed time
- D. Programming indicator: lights up during program mode
- E. Track number display: indicates the track being played
- F. Repeat indicator: lights up when repeat mode is enabled

⑥ Remote Sensor

The remote sensor receives signals from the remote control unit. Aim for this sensor when using the remote control unit. The remote control unit may malfunction if there are any obstacles between the remote control unit and the remote sensor.

⑦ CD Door

Open the CD door by hand when placing a compact disc on the tray.

Inside the CD Door

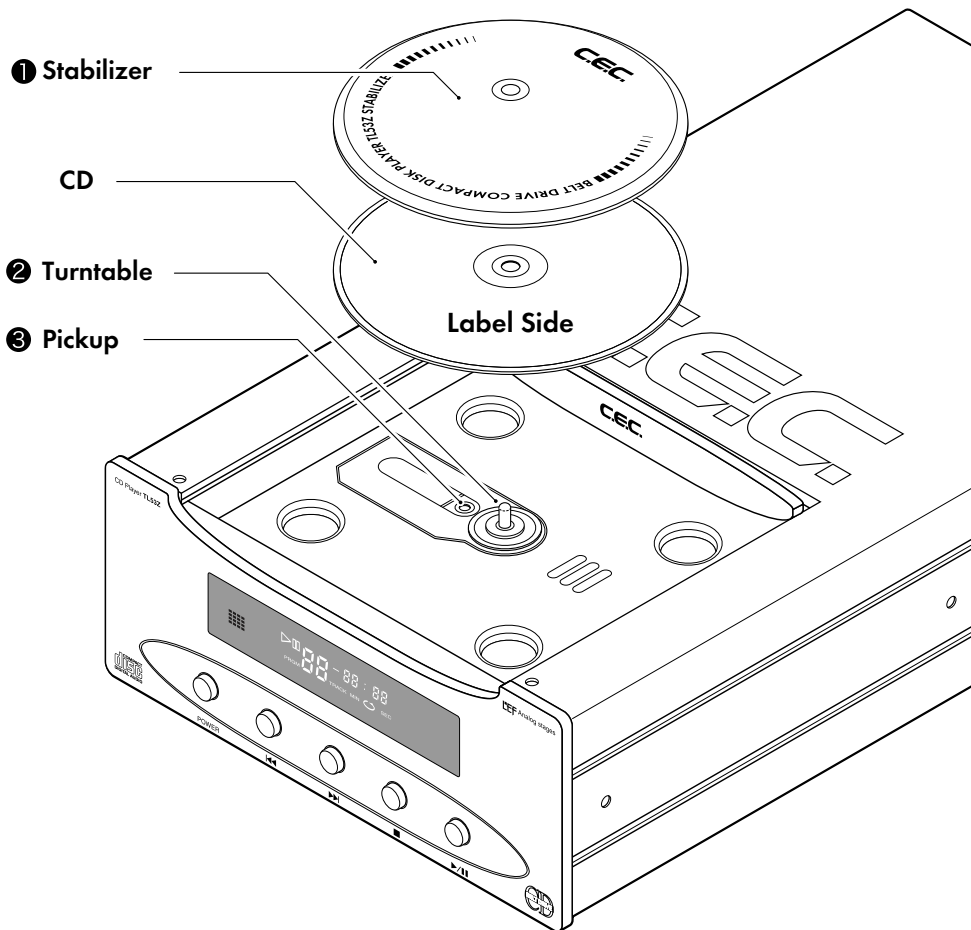

① Stabilizer

The TL53Z's stabilizer is rather large and heavy, at a diameter of 12cm and weighing 120g. Dropping the stabilizer may damage it and decrease playback accuracy, so handle with care.

② Turntable

Place a compact disc on the turntable, and place the stabilizer on top of the disc. The stabilizer can be left on the turntable when not in use.

③ Optical Laser Pickup

Read signals from the compact disc. Never touch the pickup with your fingers, etc.

Rear Panel Functions

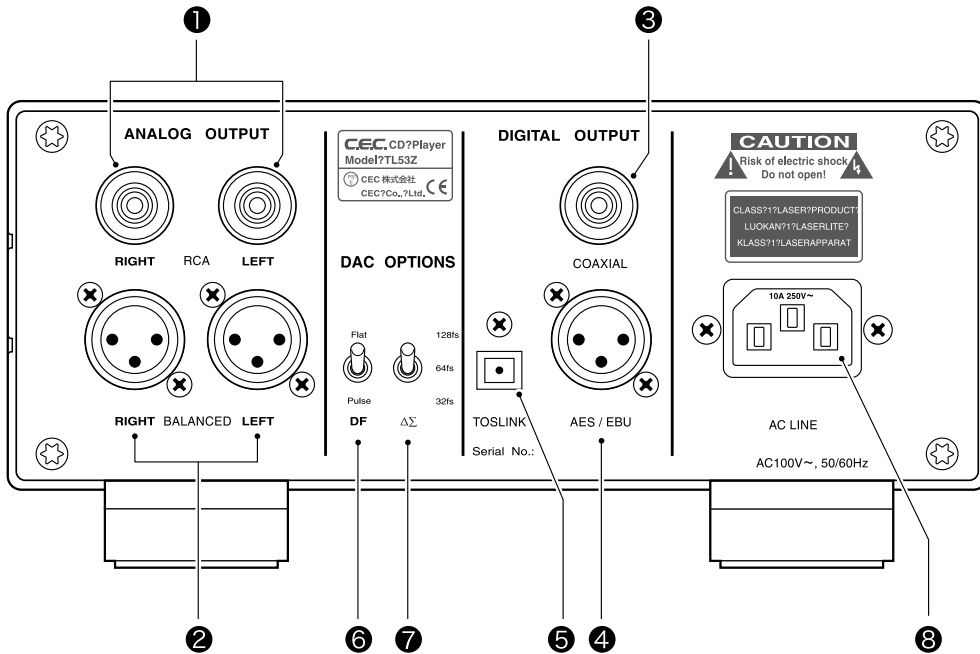

ANALOG OUTPUT

① RCA (Unbalanced)

Line out audio signal output jacks equipped with unbalanced RCA connectors. Use interconnect RCA cables to connect to an amplifier.

② XLR (Balanced)

Line out audio signal output jacks equipped with balanced XLR connectors. Use interconnect XLR cables to connect these XLR outputs to an amplifier with XLR line inputs, such as the AMP53.

(Pinning: 1=Ground, 2=Hot, 3=Cold)

The TL53Z is designed with a fully balanced circuit - using a balanced connection is recommended to maximize its performance.

DIGITAL OUTPUT

③ COAXIAL

Standard digital (SPDIF) signal output jack with a RCA type connector.

Connect to a digital audio device with a coaxial RCA input by using a RCA (75 Ω) cable.

④ AES/EBU (Balanced)

Connect to a digital audio device with a AES/EBU(XLR) input by using a XLR 110 Ω cable.

(Pinning: 1=GND, 2=Hot, 3=Cold)

⑤ TOS LINK (Optical)

Connect to a digital audio device with a TOS LINK Optical Digital input by using a optical cable.

DAC OPTIONS

⑥ DF Switch

Toggles between two settings for the Digital Filter. "Flat" is optimized for best frequency response and sharp filtering of ultrasonic noise; "Pulse" is optimized for best dynamic response while avoiding filter ringing.

⑦ $\Delta\Sigma$ -Over sampling Switch

The $\Delta\Sigma$ -Over sampling setting allows fine adjustment of the sound characteristic. A low value (32fs) has the smallest impact on the original signal and the highest dynamic response. A high value (128fs) quiets the sound and delivers the lowest disturbance in the ultrasonic frequency spectrum.

NOTE: The optimum combination of Digital filter and $\Delta\Sigma$ -Over sampling rate depends on the source, such as recording conditions, etc. You may need to experiment to determine the best setting for a disc.

⑧ AC LINE

Connect the supplied AC power cord to the AC LINE inlet.

Operation

Normal Playback

1. Push the POWER button to turn the power on.
2. Open the CD door by sliding it towards the back of the TL53Z with your hand.

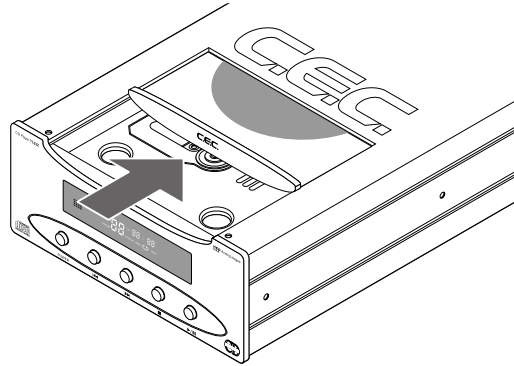

3. Place a disc on the turntable, and place the supplied stabilizer gently on top of the disc.

NOTE: Make sure you place the disc on the turntable with the label side facing up, and place the stabilizer on the disc before closing the CD door.

Use only the provided CD stabilizer. Do not use commercially available stabilizers.

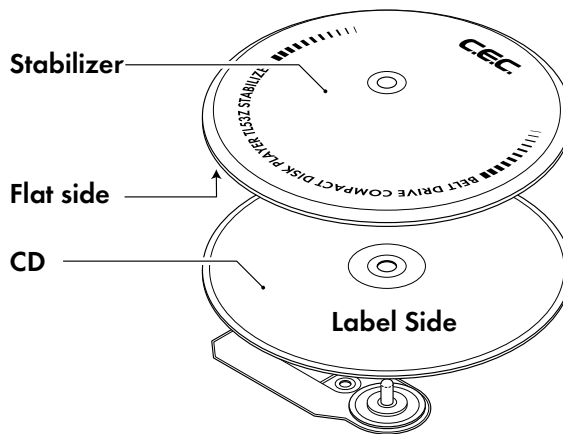

4. Close the CD door by sliding it towards the front of the TL53Z with your hand. The disc automatically starts spinning for reading its information, and the display

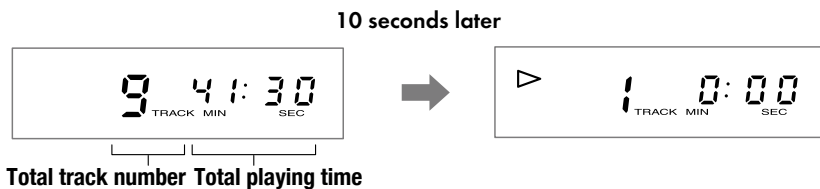

should indicate the total number of tracks and the total playing time.

NOTE: The unit cannot read the disc unless the CD door is closed completely.

5. Push the PLAY/PAUSE (▶/||) button to start playback.

The playback indicator and track number should be shown on the display, followed by the elapsed time for the track being played.



Pausing Playback

Push the PLAY/PAUSE (▶/||) button to stop playback temporarily. Push this button again to resume playback.

Stopping Playback

Push the STOP button (■) to stop playback.

NOTE: Playback will be stopped automatically if you open the CD door without pushing this button, but it will take a few seconds for the turntable to stop spinning. Do not touch the stabilizer or the disc until they stop completely. Touching the stabilizer or disc while they are still turning may damage or cause the unit to malfunction.

Removing a Disc

Slide the CD Door open with your hand, and remove the stabilizer and disc together from the turntable. Separate the disc and the stabilizer, and replace the stabilizer on the turntable. Close the CD Door.

NOTE: Discs will tend to adhere to the stabilizer when taken out. Make sure not to drop the disc by accident.

Do not leave discs on the turntable when the TL53Z is not in use. The stabilizer can be kept on the turntable when unused.

Remote Control Unit

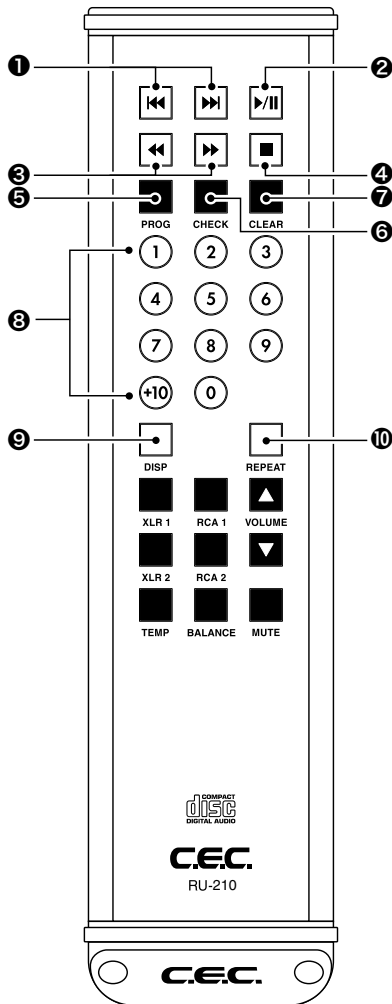

❶ ◀◀ Track Skip (Backward) / ▶▶ Track Skip (Forward) Buttons

Jumps to the previous or next track from the track being played (or displayed).

❷ PLAY/PAUSE Button (▶/||)

Press this button to start playback or to pause playback temporarily.

❸ ◀◀ Search (Backward) / ▶▶ Search (Forward) Buttons

Press and hold these buttons to quickly search through the current track.

◀◀ searches through the track backwards,

▶▶ searches forwards.

NOTE: There are no Search buttons on the front panel of the TL53Z.

❹ Stop Button (■)

Press this button to stop playback.

❺ PROG Button

Press this button to enable programmed playback. You can program up to 32 tracks to playback in the order of your choice.

*Refer to "PROGRAMMED PLAYBACK" on page 20 for details.

❻ CHECK Button

Press this button to check the order of the tracks in your current programmed setting.

*Refer to "PROGRAMMED PLAYBACK" on page 20 for details.

❼ CLEAR Button

Press this button to clear your current programmed setting.

*Refer to "PROGRAMMED PLAYBACK" on page 20 for details.

8 Numeric keys

Use these keys to select tracks directly during playback, or when entering a programmed playback order.

9 DISP (Display) Button

Press this button to cycle the TL53Z's display through its various modes. Each press of the DISP button cycles the display in the following order: track number/elapsed track time (default display) → track number/remaining track time → total remaining time → total elapsed time → back to track number/elapsed track time (default display).

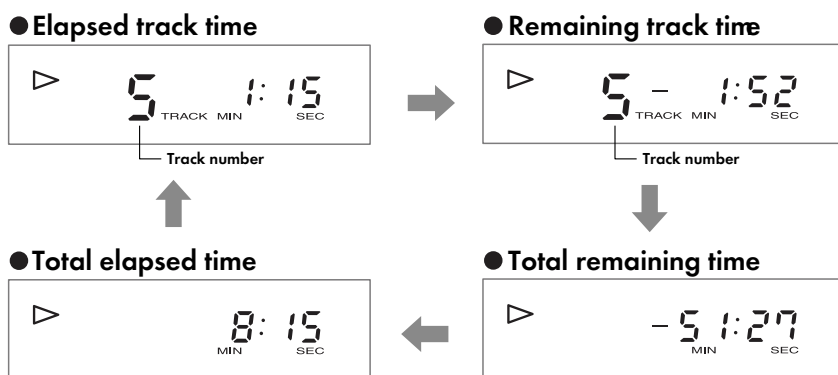

10 REPEAT Button



Press this button to repeat playback all the tracks on a disc. When the repeat mode is on, the display will show the repeat indicator (↻). Press this button again to cancel the repeat mode.

NOTE: The other buttons on the remote control unit are used with other CEC products, such as the AMP53 amplifier, but are not used for the TL53Z.

Programmed Playback

You can program up to 32 tracks in a customized playback order, by using the remote control unit while playback is stopped.



- (1) Press the **PROG** button on the remote control unit. The “PRGM” indicator will appear in the display, and the track number 1 should be shown blinking.
- (2) Select a track number by pressing the numeric keys on the remote control unit. The selected track will be added to the program. Repeat this process to program additional tracks.
- (3) Press the **STOP** button to complete the programming phase.

Playback in Program Mode

Press the **PLAY/PAUSE** (▶/||) button while the “PRGM” indicator is shown on the display to play the programmed tracks.

NOTE: To return to the normal playback mode, press the **PROG** button while playback is stopped. The “PRGM” indicator will disappear from the display.

*To return to the program mode, press the **PROG** button again.

Checking, Adding, Changing and Clearing Programmed Tracks

You can check, add, change and clear the programmed tracks under the program mode while playback is stopped.



Check the Playback Order for the Programmed Tracks

Press the CHECK button repeatedly to show the playback order for the programmed tracks. The display changes to “- -” when you reach the last track in the program. Pressing the CHECK button again here will display the first track in the playback order.

NOTE: If you press the STOP button (■), the display will jump back to the first track in the programmed order.

Adding Tracks to the Program

To add one track to the current program, press the STOP button and select the track number with the numeric keys. The new track will be added to the end of the current playback order. Repeat this process to add more tracks to the program. Press the STOP button to complete the track-adding phase.

Changing Tracks in the Program

To change one track in your programmed playback order, press the CHECK button repeatedly until the track number in question is displayed, then select a new track number. The new track will overwrite the existing track. Repeat this process to change more tracks. Press the STOP button to finish the track-changing phase.

Clearing Programmed Tracks

To clear the entire program, hold down the CLEAR button for more than 2 seconds.

To clear one track from the program, press the CHECK button repeatedly until the track number in question is displayed, then press the CLEAR button.

Repeat this step (CHECK → CLEAR) to remove more tracks from the program.

*The entire program will be cleared automatically when you open the CD Door or turn the power off.

Precautions on Using the Remote Control Unit

- When operating the remote control, point it towards the remote sensor on the TL53Z's front panel. Make sure nothing is blocking the front panel where the remote sensor is located.
- Avoid exposing the remote sensor on the front panel to direct sunlight or other light sources, as such exposure can cause malfunction.
- The remote control unit may malfunction when its batteries are running low. Change the batteries to new ones of the same type if this seems to be the case.
- The remote control unit is very heavy and should be handled with care. Dropping it on fragile surfaces (e.g. glass tables) can result in damage.



Battery Installation

Unscrew the battery compartment cover using a Philips screwdriver, and remove the cover. Insert the supplied two AA batteries into the compartment. Make sure that the batteries are inserted with their positive (+) and negative (-) poles positioned correctly, and screw the cover back on.

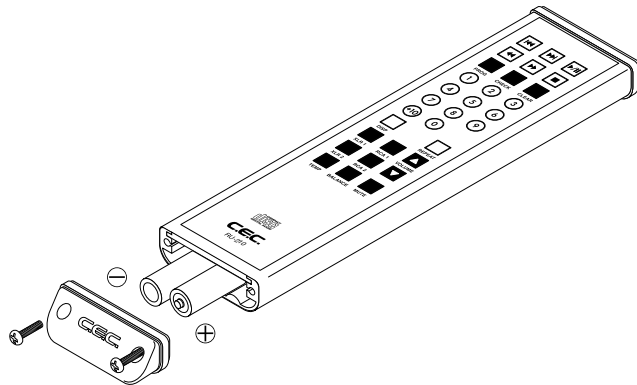

Battery Replacement

If the distance at which the remote control unit can be used to operate the TL53Z seems to be decreasing, replace both batteries with new ones.

Battery Precautions

- Never use different types of batteries together. Both rechargeable or non-rechargeable batteries can be used, but the two should not be used together.
- If you will not be using the remote control unit for an extended period of time (more than a month), remove the batteries to prevent leakage.

- If the batteries leak, use a cloth to wipe away the liquid inside the battery compartment and replace the batteries with new ones.
- Do not heat or disassemble batteries, and never dispose of old batteries by throwing them in a fire. Dispose of batteries following laws in the local area.

Cautions Regarding Handling

- Should you ever open the CD Door without press the STOP button, do not touch the stabilizer and the disc until the turntable has stopped spinning completely. Touch them while they are still spinning may cause stress on the spinning mechanism and lead to malfunction.
- Discs tend to adhere to the stabilizer when removing the latter from the turntable. Make sure you do not drop the disc by accident.
- To prevent vibrations from the surroundings and maximize the sound quality and performance, this unit should be set on an audio rack or a firm board.

- **Belt and Spindle Replacement**

The TL53Z uses a belt drive mechanism. The belt will gradually deteriorate over time. Possible symptoms resulting from this are; failure to read TOC, sound skipping, etc. You will need to have the belt replaced in such cases. We recommend replacing the belt at least once every 5 years. Please contact your dealer or an authorized CEC service center.

Likewise, the spindle will also gradually deteriorate over time. We recommend an overhaul at least once every 10 years.

Maintenance

- If the surface of the TL53Z case becomes soiled, wipe with a soft cloth or use diluted neutral cleaning liquid. Be sure to remove any fluid completely. Do not use thinner, benzene, alcohol, chemical cloths or bleaching agents as these may damage the surface of the TL53Z case. Also avoid using aerosol insecticides near the unit.
- If dust accumulates on the turntable, remove it with stick tape (e.g. Scotch tape). Make sure not to touch the optical pickup lens with your fingers.
- The TL53Z requires no periodic maintenance except the belt and spindle replacement mentioned above, and contains no user-serviceable parts. Contact your dealer or an authorized CEC service center for inspection and repairs in case of malfunction.

Troubleshooting

- **No power**
 - ➔ Check the connection at the both ends of the AC power cord.
 - ➔ Make sure there is power at the wall outlet.

- **No Playback**
 - ➔ Check that the disc is placed with its label facing up.
 - ➔ If the disc is soiled, clean the surface of the disc.

- **No sound**
 - ➔ Check the connection to the amplifier.
 - ➔ Check the position of the input selector of the amplifier.

- **Sound skipping**
 - ➔ Place the player on a stable rack to prevent the effects of vibration
 - ➔ If the disc is soiled, clean the surface of the disc.
 - ➔ Do not use scratched, damaged or warped disc.

- **Humming noise**
 - ➔ Check that the pin plugs are connected adequately.

- **Interference on the tuner**
 - ➔ The tuner is too close to the TL53Z. Install the TL53Z away from it or turn off the tuner's power.

- **Unresponsive to remote control**
 - ➔ Point the remote control towards the remote sensor on the front panel.
 - ➔ Remove any objects blocking the sensor.
 - ➔ Use the remote control unit at a shorter distance from the TL53Z.
 - ➔ Replace the batteries in the remote control unit with new ones.

NOTES: The TL53Z contains a microcomputer that can malfunction due to external noise or interference. If this seems to be the case, turn the unit off and wait for a short while before turning it back on and trying again.

Specifications

AUDIO	
Playable Discs	Audio CDs & Finalized CD-R/RWs recorded in audio CD format
Frequency Response	20Hz - 20kHz, +0/-0.35dB
S/N Ratio	RCA: -101dB, XLR: -125dB (flat)
Harmonic Distortion	RCA: 0.014%, XLR: 0.005% (0dB, 32fs)
Channel Separation	RCA: <-113dB XLR: <-123dB (1kHz, 0dB)
Dynamic Range	RCA: 97dB, XLR: 98.5dB
DAC	
DAC	Burr-Brown PCM1792×2
$\Delta\Sigma$ Over sampling rates	32fs, 64fs, 128fs (selectable)
Digital Filter	Flat, Pulse (selectable)
OUTPUT	
Analogue Output	RCA (2Vrms) ×1 XLR (4Vrms) ×1 (Hot=2)
Digital Output	TOSLINK×1 COAXIAL(SPDIF)×1 AES/EBU(Balanced XLR;HOT=2) ×1
Optical Pickup	
Type	SF-P101NXR
Manufacturer	SANYO Electric Co., Ltd.
Laser Output	Less than 0.5mW on the objective lens
Wave Length	765 - 815nm (CD)
GENERAL	
Power Supply	AC120/240V, 50/60Hz (specified on rear panel)
Power Consumption	16W
Dimensions	Approx.217.5(W) ×448(D) ×111(H) mm (incl. knobs and terminals)
Weight	Approx. 7.2 kg
Accessories	AC Power Cord, Stabilizer, Remote Control Unit, Two AA type batteries Owner's Manual
Color	Silver

* Design and specifications are subject to change without notice.

* Illustrations in the Owner's Manual may deviate from the actual unit due to design improvements.

CEC

CEC Co., Ltd. Japan
